

ionopticks



Aurora **3**[™] GENERATION

IonOpticks accessories featured in these guidelines:

IonOpticks 5cm Rapid Column Housing (5CMNFSH1)
IonOpticks TS Nanospray Flex Adapter (TSFLXAD01)
IonOpticks SX Installation Toolkit (SXITK01)
IonOpticks Column Heater (COLHTR01)
IonOpticks Heater Controller (IOHEATCON1)
IonOpticks Column Heater Extension Cable (EXTCABLE03)

User Guide

Aurora Series[™] UHPLC packed emitter columns

Recommended guidelines for optimal setup and operation of Aurora Series columns:

Aurora Frontier
AUR3-60075C18
AUR3-60075C18-CSI
AUR3-60075C18-TS

Aurora Rapid150
AUR3-50150C18
AUR3-50150C18-CSI

Aurora Ultimate
AUR3-25075C18
AUR3-25075C18-CSI
AUR3-25075C18-TS
AUR3-25075C18-SX

Aurora Rapid75
AUR3-5075C18
AUR3-5075C18-CSI

Aurora Elite
AUR3-15075C18
AUR3-15075C18-CSI
AUR3-15075C18-TS
AUR3-15075C18-SX



Product Features	3
Compatibility	3
Video installation guides	4
Setting up the IonOpticks Heater and Heater Controller (COLHTR01 and IOHEATCON1)	5

Fitting Aurora Series columns to your UHPLC system

For Bruker CaptiveSpray source	6
Using Bruker Column Toaster	7
Using Sonation Column Oven (PRSO-V1 and PRSO-V2)	8
For Thermo Scientific Nanospray Flex source	9
with Sonation Column Oven (PRSO-V1 and PRSO-V2)	9
with an IonOpticks 5cm Rapid Column Housing (5CMNFSH1)	10
with an IonOpticks TS Nanospray Flex Adapter (TSFLXAD01)	11
For Thermo Scientific EasySpray Source	13
with a TS column into an EasySpray source (ES081 and ES082)	13
For SCIEX OptiFlow Turbo V Source	14
with an SX column using an SX installation toolkit (SXITK01) on an OptiFlow nanoflow probe	14

Operation of Aurora Series columns

Initial operation	16
Standby and idle conditions	16
Spray voltage	16
Operating environmental conditions	16
Removal from a UHPLC	16
Recommended buffer compositions	16
Column volumes	16
Column temperature	16
Column equilibration	16
Sample loading	16
Example data	16

Recommended gradients

DISCLAIMER: The use of “we” “us” or “our” in this User Guide are references to IonOpticks Pty Ltd ACN 621 674 459. The information in this User Guide including (without limitation) the recommendations, safety guidelines and product warnings with respect to the use of our products are to be read strictly subject to our terms and conditions which can be located at www.ionopticks.com and the limitations and exclusions of our liability found within those terms. Products should not be used if they appear damaged. We accept no liability for any loss or damage howsoever or wherever arising (including death and/or personal injury) which results from or is connected with the failure by the customer to use our products strictly in accordance with the directions in this User Guide.

Innovative Design. Transforming Proteomics.

Our columns are differentiated by two key technological advances: a unique packed emitter design that enables maximum mobile phase velocity with no post-column dead volume; and our own nanoZero® technology that provides user friendly 'plug and play' connections with true zero pre-column dead volume. Together, these features combine to maximise chromatographic efficiency and dramatically enhance performance, providing a best in class solution for peptide and metabolite LC-MS separations.

Product Features

- ✓ Integrated emitter with zero post-column dead volume.
- ✓ Pre-fitted with nanoZero® to provide a zero-dead-volume female union between a nanoViper™ Fingertight fitting (or equivalent) and the Aurora series column.
- ✓ nanoZero® fitting incorporates a 10-32 internal thread for easy installation.
- ✓ Designed to withstand ultra-high-performance LC (UHPLC) backpressures of >1700 bar.
- ✓ nanoZero® is electrically conductive to allow a voltage connection to the entrance of the column.

Compatibility.

Aurora columns are compatible with a wide range of LC-MS systems. Compatibility is not limited to equipment presented in this guide. For further information about instrument compatibility, please visit helpcentre.ionopticks.com

Mass Spectrometer Ion Sources

- Thermo Scientific EasySpray
- Thermo Scientific Nanospray Flex
- Bruker CaptiveSpray
- SCIEX OptiFlow Turbo V
- Newomics UniESI source
 - Thermo NG
 - Agilent

UHPLC

- Bruker nanoElute
- Bruker nanoElute 2
- Evosep One (Whisper methods only)
 - Aurora Elite; 20SPD, 40SPD
 - Aurora Rapid75; 80SPD
- Thermo Scientific Dionex UHPLC systems
- Thermo Scientific Easy-nLC 1000 / 1200
- Thermo Scientific Vanquish Neo
- Waters M-Class
- Waters nanoAcquity

Fittings

- Thermo Scientific nanoViper
- Waters ZenFit

Column Ovens

- IonOpticks Column Heater
- Bruker Column Toaster
- Sonation Column Oven

Performance guarantee

Our columns are subjected to rigorous quality control procedures under the direct eye of our Senior Scientists. All IonOpticks products are covered by our 100% performance guarantee. Any item not meeting our high-performance expectations due to manufacturing defects will be replaced without charge to the customer.

Please contact us at support@ionopticks.com if you have any concerns relating to your column. Our terms and conditions are provided with every quote, but we want to make sure you are receiving a quality product every time so please do not hesitate to get in touch with any feedback or concerns.

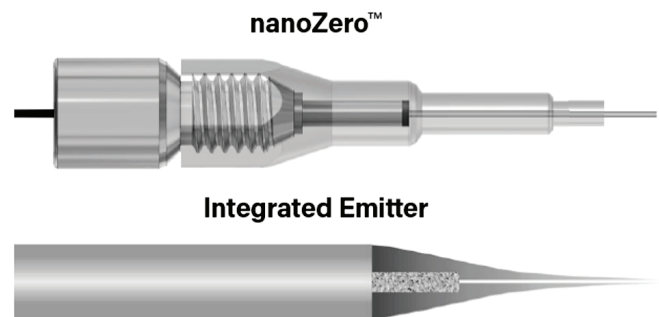

Product Specifications.

Column format:	Analytical column
Column type:	Reversed-phase
For use with:	UHPLC
Pore size	120Å
Max pressure	>1700 bar
Temp limits	60°C (low pH)
Particle size	1.7µm
pH stability	1-8
Stationary phase	C18

CAUTION Handling of fused-silica or glass tubing and tips can result in serious personal injury, including eye and skin injury. Use safety goggles meeting AS/NZS 1336 requirements or equivalent. Puncture and chemical-resistant gloves should also be worn at all times.

Video installation guides.

Access to online video content

We've created a series of online tutorials for easy setup, information on compatibility and useful tips.

To watch installation videos specific to your laboratory setup, visit helpcentre.ionopticks.com and search for "Installation Guides".

For all other online content, find us on social media @IonOpticks, or see our videos on YouTube at www.youtube.com/@ionopticks

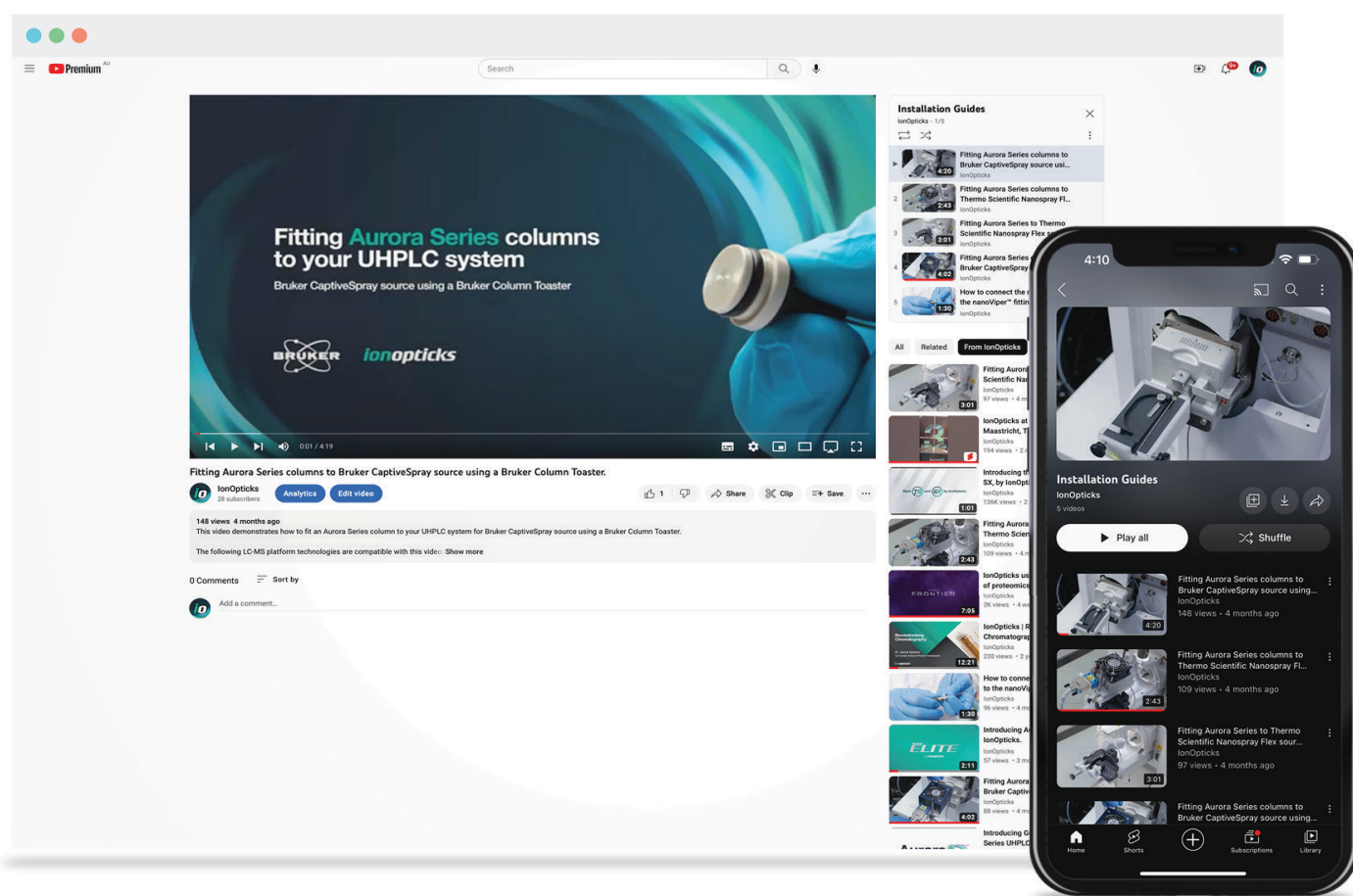

Regulatory Compliance

IonOpticks evaluates its products to ensure full compliance with applicable North American and European regulations. The IonOpticks columns, used in conjunction with the column heater, heater controller and other accessories, are intended for use in the basic electromagnetic environment as defined in IEC 61326-1. For detailed information on emission level and permissible performance under the electromagnetic immunity conditions, please contact IonOpticks.

IonOpticks products are compliant with the Restriction of Hazardous Substances (RoHS) directive. This equipment has been tested and found to comply with the limits for a Class A digital device, pursuant to part 15 of the FCC Rules. These limits are designed to provide reasonable protection against harmful interference when the equipment is operated in a commercial environment. This equipment generates, uses, and can radiate radio frequency energy and, if not installed and used in accordance with the instruction manual, may cause harmful interference to radio communications. Operation of this equipment in a residential area is likely to cause harmful interference in which case the user will be required to correct the interference at their own expense.

Changes or modifications to these products not expressly approved by the party responsible for compliance could void the user's authority to operate the equipment.

Setting up the IonOpticks heater and heater controller. (COLHTR01 and IOHEATCON1)

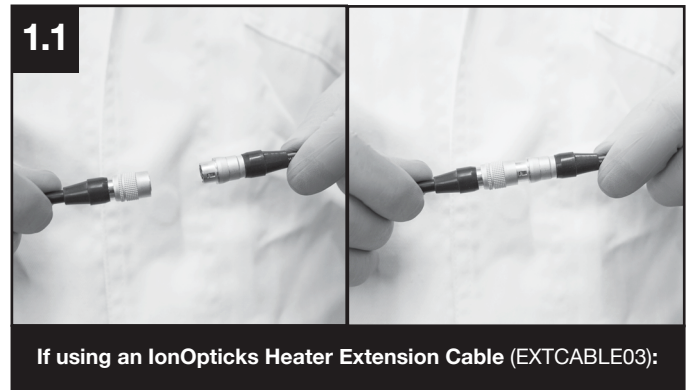

2 Ensure settings on the heater controller unit match these found here:

1.2 Plug extension cable into channel 1 of IonOpticks Heater Controller unit. Plug cable from IonOpticks heater into the receiving plug on the Heater Extension Cable



Note: Only a single extension cable can be used with the IonOpticks Heater. The use of multiple extension cables may cause a failure in the operation of the heater and could damage the IonOpticks Heater and IonOpticks Heater Controller.

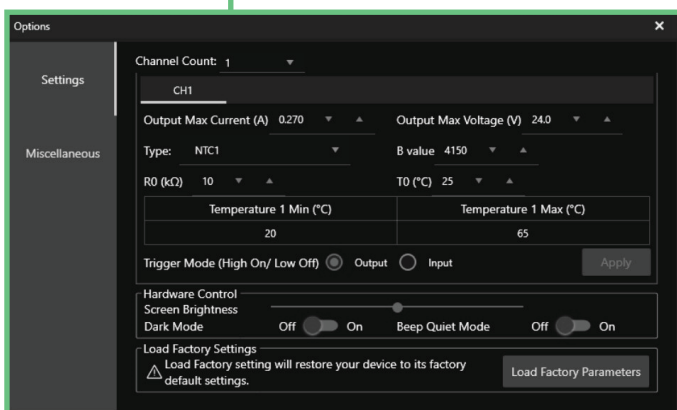
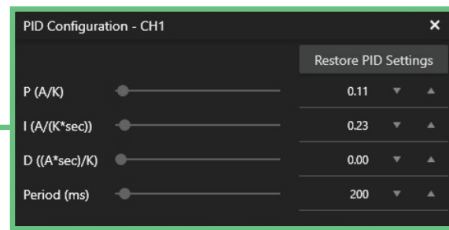

3 Set heater to desired temperature. We recommend using a temperature between 40-60°C. The maximum recommended temperature is 60°C.

4 The heater is now installed and ready for use.

Heater Rating
 24 V, 0.8A, 20 W

This device complies with part 15 of the FCC Rules. Operation is subject to the following two conditions: (1) This device may not cause harmful interference, and (2) this device must accept any interference received, including interference that may caused undesired operation.

For Bruker CaptiveSpray source.

1 Unscrew CSI probe from CSI housing

2 Disassemble rear metal housing of CSI probe insert (2 screws)

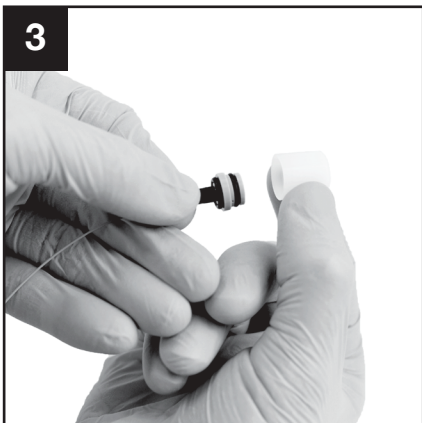

Carefully remove Aurora CSI protective cap.

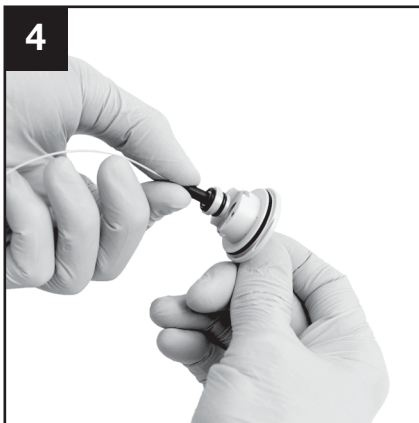

Insert Aurora CSI fitting into CSI probe. Insert using a twisting motion to prevent pinching of rubber seal.

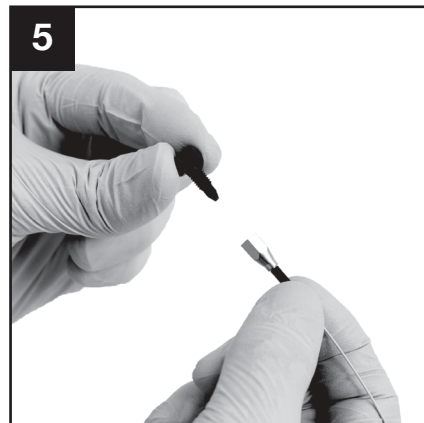

Remove the protective plug from the nanoZero® union.

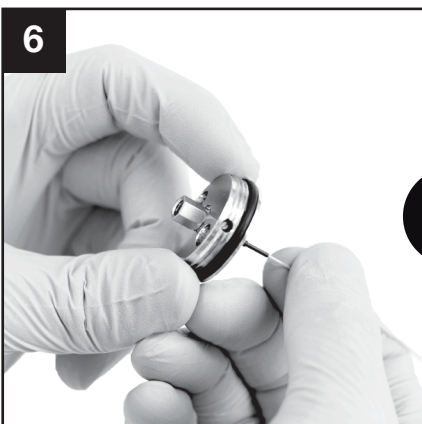

Feed Aurora column through the rear metal housing and reassemble CSI probe (2 screws), ensuring rubber seal is in place between metal housing and Aurora CSI fitting.



Feed Aurora column with nanoZero® fitting through CSI probe housing.

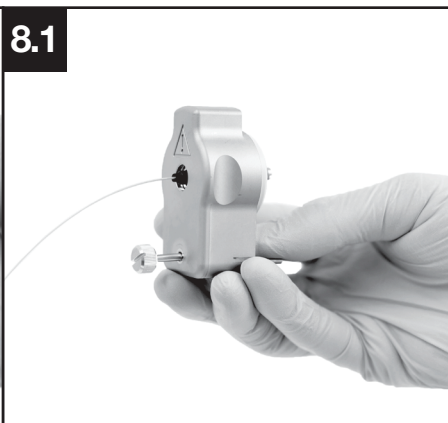
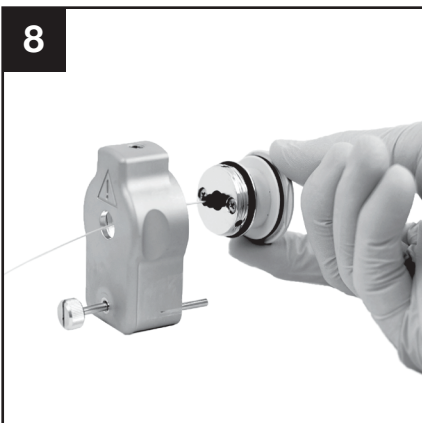

Feed column through CSI housing and screw CSI probe insert into housing.



The CSI housing is now ready to connect to your LC-MS system.

For Bruker CaptiveSpray source if using Bruker Column Toaster

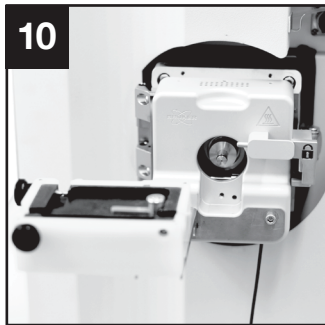

10
Retract the column heater from the CaptiveSpray source

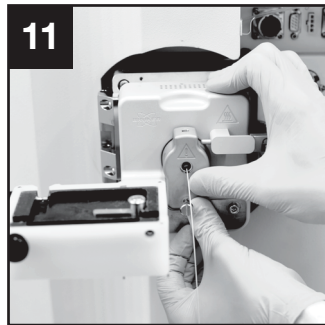

11
Insert the CSI Housing into the source, press with a small amount of pressure and tighten the screw until finger tight.

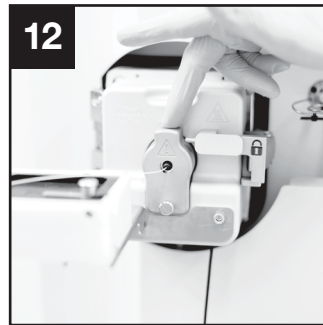

12
Using a gloved finger, block the air inlet and monitor the Fore pressure. The Fore vacuum needs to drop to below 3e-01 mbar within 10 seconds to be considered usable.



13
Move the column heater in front of the CaptiveSpray source.

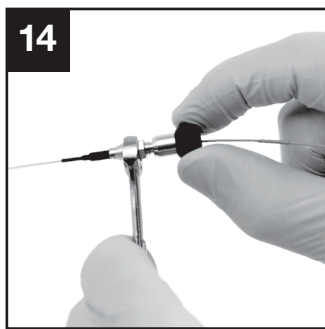

14
Holding the nanoZero® with a spanner, tighten the nanoViper fitting finger tight until you reach a firm stop.

If not sealed, try refitting before replacing rubber seals (Refer Bruker CSI troubleshooting guide).

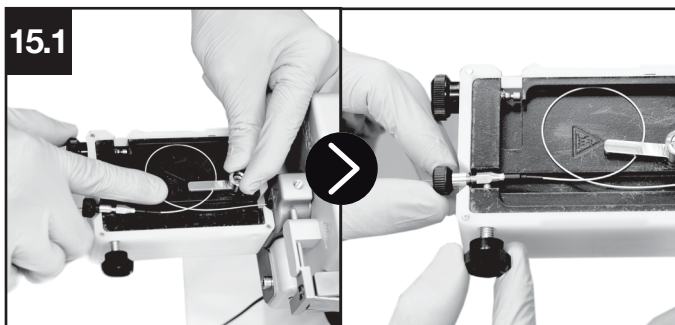

15.1
For Aurora Frontier, Aurora Ultimate and Aurora Elite columns

Curl the column inside the heating plate and hold in position by placing under the holding arm.

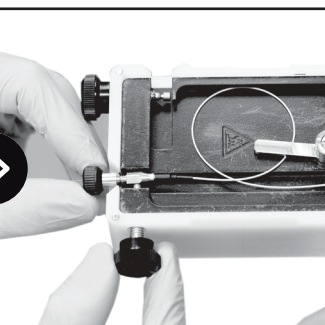

Tighten the earth screw onto the nanoZero® to ensure that the nanoZero® is grounded and held in position.

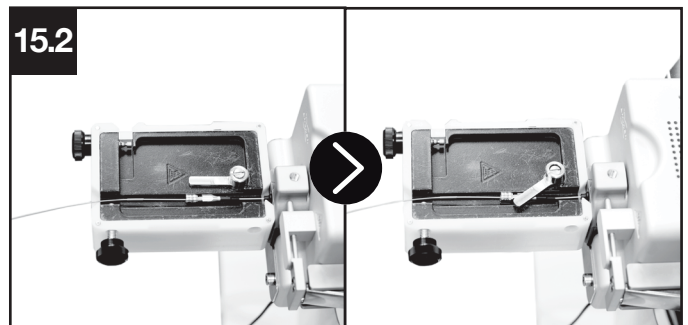

15.2
For Aurora Rapid75 and Aurora Rapid150 columns

Place column directly into the heater recess. Hold in position by placing the holding arm onto the nanoZero®. This requires a replacement metal holding arm (supplied by IonOpticks) to allow an earth connection with the nanoZero®.

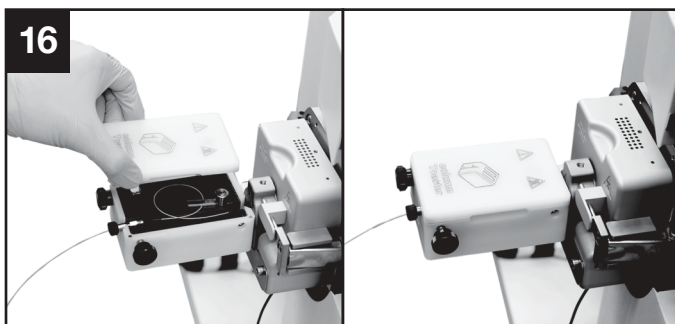

16
Place lid on heater

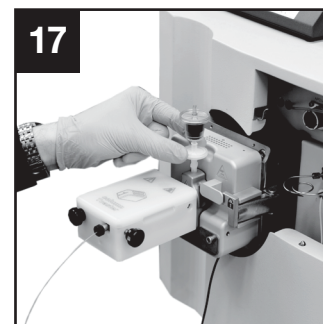

17
Install filter into the CSI housing air inlet.

The column is now installed in the heater and ready for operation.

For Bruker CaptiveSpray source

if using Sonation Column Oven (PRSO-V1 and PRSO-V2)

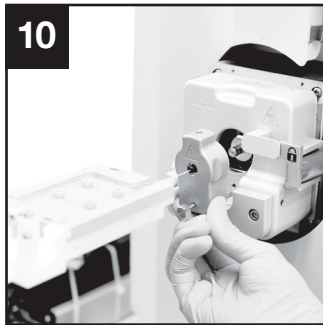

10 Retract the column heater from the CaptiveSpray source



11 Press the CSI Housing with a small amount of pressure and tighten the screw until finger tight.

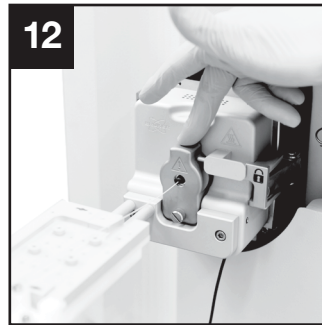

12 Using a gloved finger, block the air inlet and monitor the Fore pressure. The Fore vacuum needs to drop to below $3e-01$ mbar within 10 seconds to be considered usable.

If not sealed, try refitting before replacing rubber seals (Refer Bruker CSI troubleshooting guide).

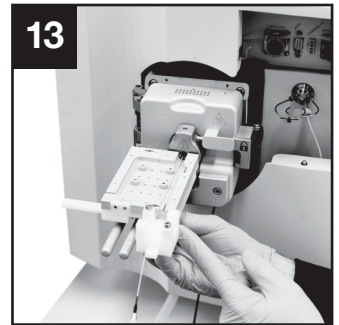

13 Move the column heater in front of the CaptiveSpray source.

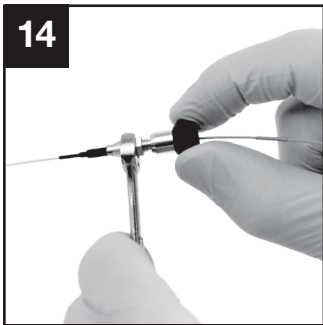

14 Holding the nanoZero® with a spanner, tighten the nanoViper fitting finger tight until you reach a firm stop.

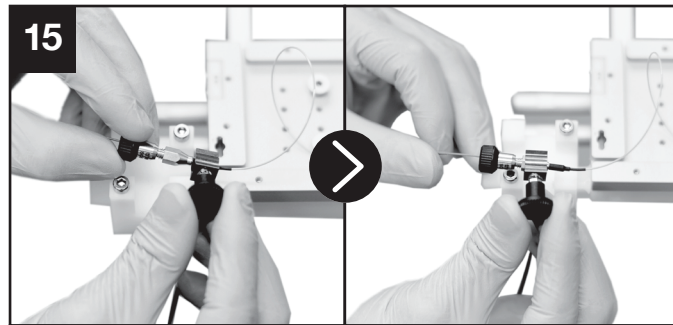

Earthing

15 Place the earth cable clip over the thin section of the nanoZero® and slide over the hexagonal section to make a firm connection. If the clip feels loose, remove the clip, pinch in the clip arms and repeat the process.

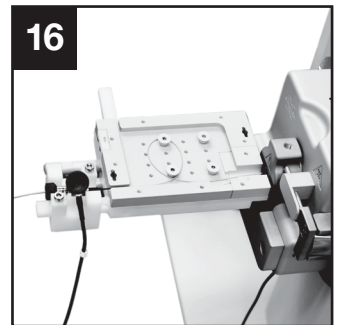

16 Curl the column inside the heating plate and place the nanoZero® and earth clip into the plastic holder.

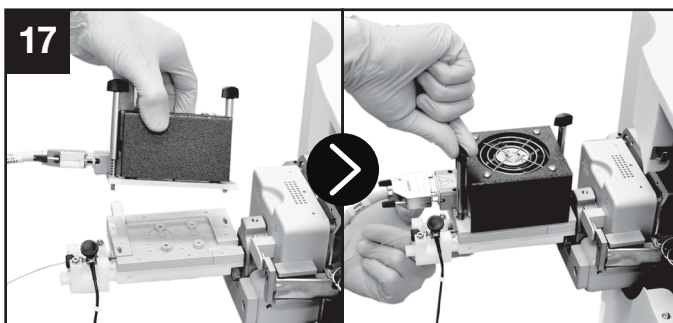

Closing the heater

17 Place top plate on heater and secure in position using the press pins. Be careful to avoid pinching the column during this process.

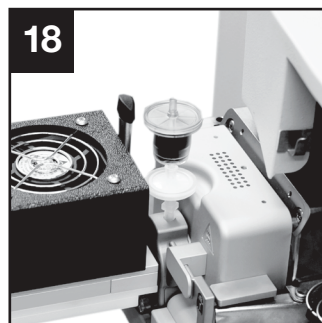

18 Install filter into the CSI housing air inlet.

The column is now installed in the heater and ready for operation.

For Thermo Scientific Nanospray Flex with Sonation Column Oven (PRSO-V1 and PRSO-V2)

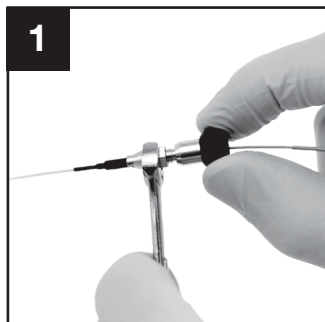

1
Holding the nanoZero® with a spanner, tighten the nanoViper fitting finger tight until you reach a firm stop.

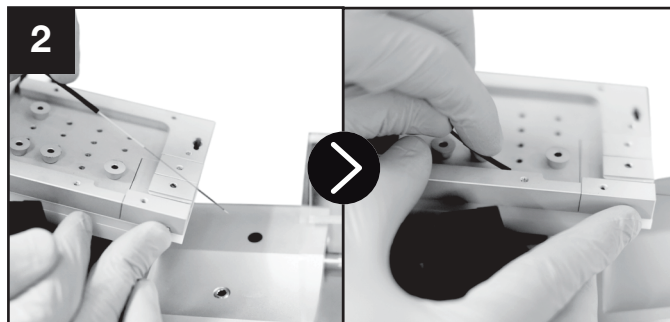

2
Preparing the column
Carefully slide protective sheath backwards towards the nanoZero® fitting to expose the emitter tip. Press the holding clamp on the heater open and place the column into the heater. The column emitter should extend 15-20mm beyond the heating plate.

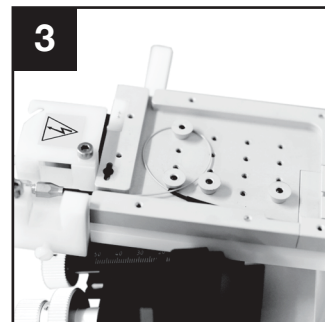

3
Curl the column inside the heating plate.

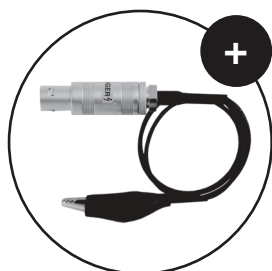

You will need:
1 x HVCABLE01
for connection of the source high-voltage to the nanoZero® fitting.

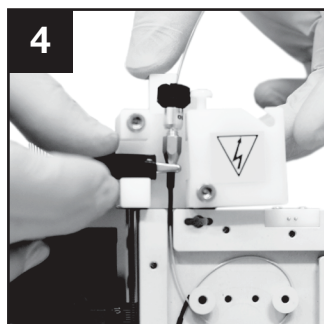

4
Connect the HVCABLE01 to the nanoZero as shown.

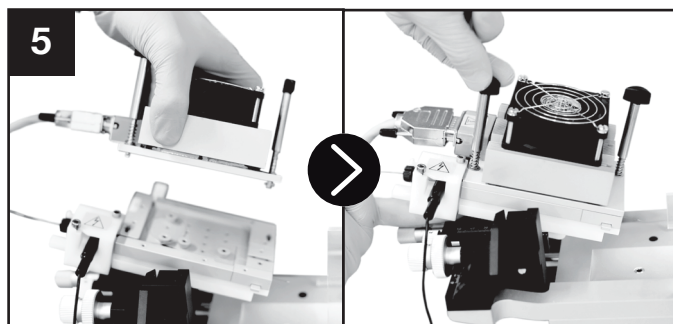

5
Place top plate on heater and secure in position using the press pins. Be careful to avoid pinching the column during this process.

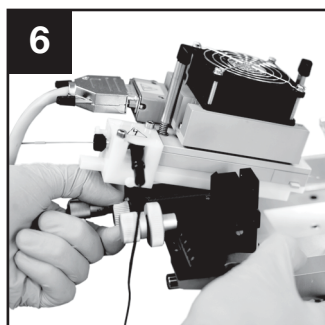

6
Ensure that the stage is fully retracted in the z-axis before moving the source towards the mass spectrometer.

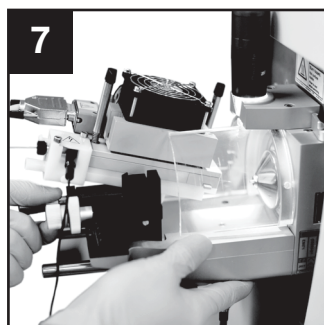

7
Slide the source into position and adjust the x, y and z axis on the stage to ensure a good emitter position. The emitter should be 3-5mm from the ion transfer capillary.

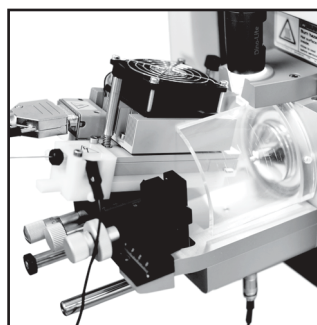

The column is now installed in the heater and ready for operation.

For Thermo Scientific Nanospray Flex with 5cm RAPID column housing (Part No. 5CMNFSH1)

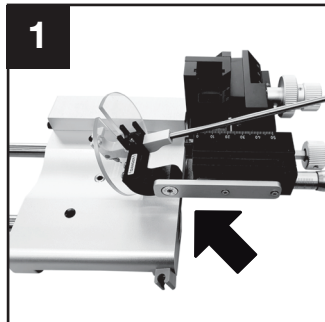

1
Unscrew and remove the existing fastening bolt, marked by the arrow, from the source.

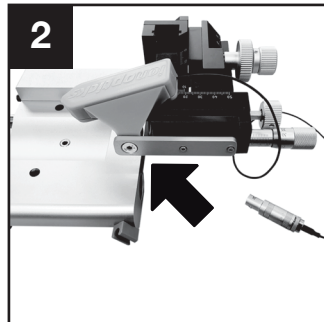

2
Attach the housing using the supplied bolt and nut. Attach the source to the mass spectrometer and plug in voltage connection into the source.

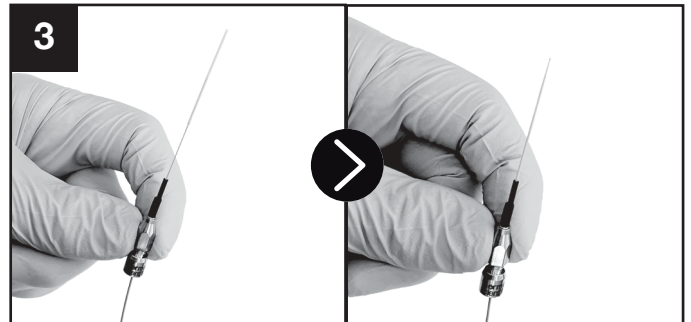

3
Fit the nanoViper into the Aurora column nanoZero® fitting. Expose the emitter tip by sliding the protective sheath towards the nanoZero®.

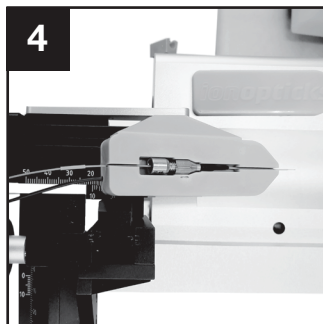

4
Install Aurora column and nanoViper line into the housing as shown.

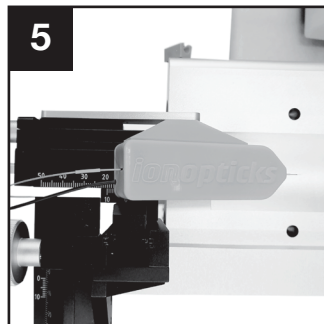

5
Place lid on housing.

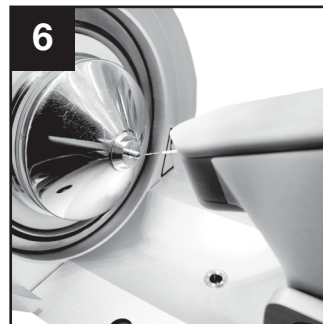

6
Manoeuvre emitter tip into the desired position using the source stage controls. The emitter should be 3-5mm from the ion transfer capillary.

The column is now installed and ready for operation.

For Thermo Scientific Nanospray Flex (ES071 and ES072)

with TS Nanospray Flex Adapter (Part No. TSFLXAD01)



Tools required

- 1.5 mm hex key
- 2 mm hex key
- 3 mm hex key
- 2 x Nanospray Flex Adapter (NSFA) screw

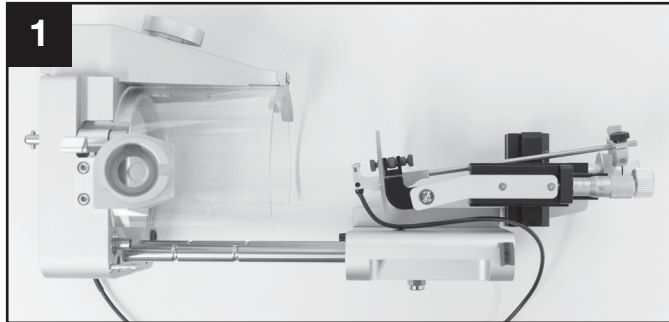

1 Place Nanospray Flex source on its side and slide the stage out.

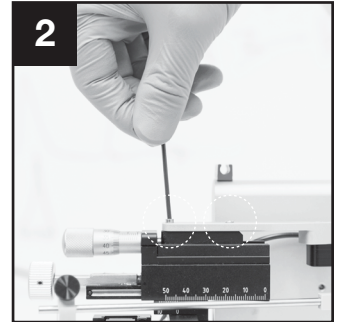

2 Using a 2 mm hex key, unscrew the two screws used to hold the mounting arm in place.

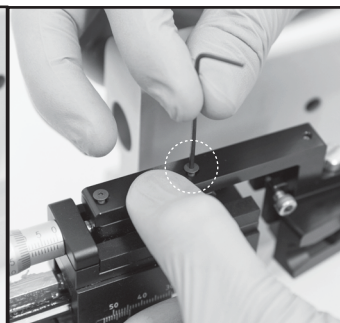
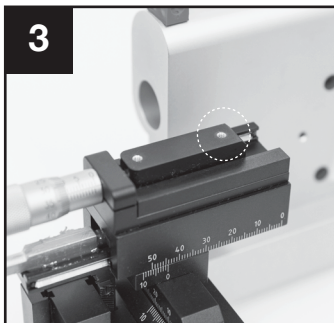

3 Using gravity to hold the screw in place, drop one NSFA screw into the central hole on the Nanospray Flex Adapter mounting arm. Align the screw with the corresponding position on the Nanospray Flex source and use a 1.5 mm hex key to tighten screw into place.

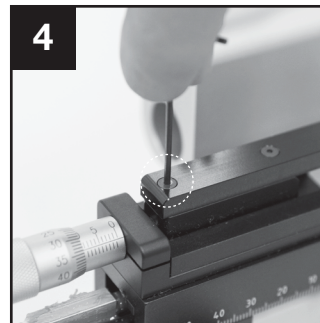

4 Screw in the remaining NSFA screw into the second hole.

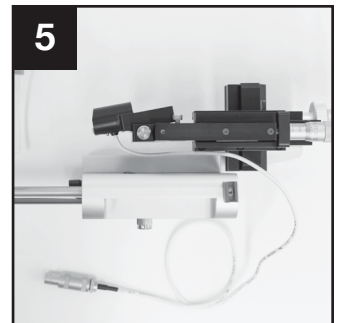

5 Ensure that the high-voltage cable runs out of the rear of the source, between the two stage rails.

Note: The high-voltage cable should not pass between the source mount and the stage.



6 Connect the high-voltage cable to the source.

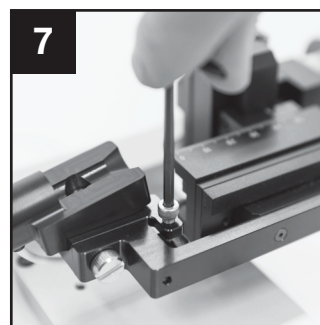

7 The angle of the column can be adjusted using the angle adjustment screw with a 3mm hex key located beside the column mount.

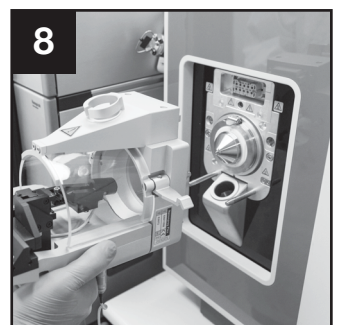

8 Slide the stage into the source mount and attach the source to your mass spectrometer.

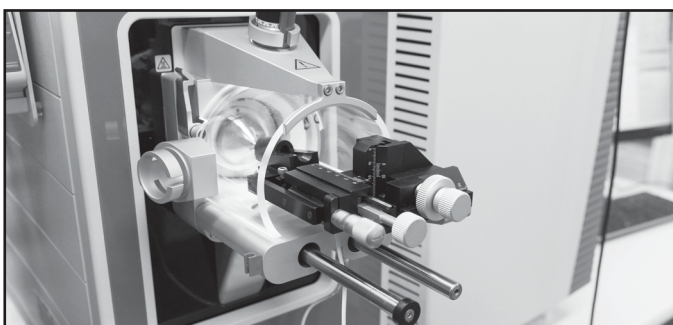

The Nanospray Flex adapter is now installed and ready for use.

Installing a TS column

using TS Nanospray Flex Adapter (Part No. TSFLXAD01)

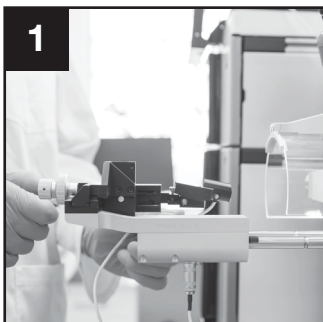

Place the mass spectrometer in standby before sliding the source stage out of the safety hood.



Retract the Z-axis control knob to prevent the emitter contacting the ion transfer tube when the column is inserted and the source stage slides into the operating position.

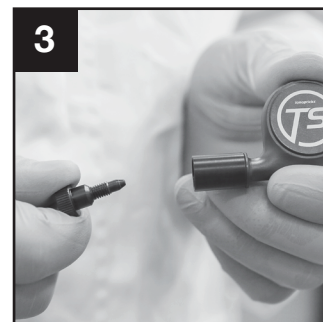
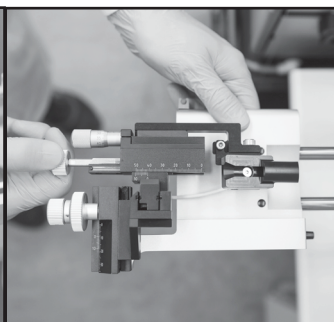

Remove the shipping plug from the column cassette.

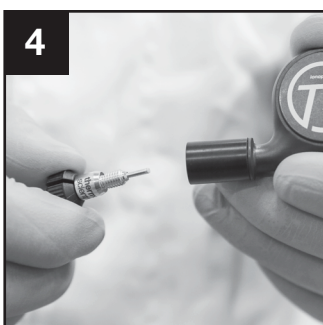

Holding the column cassette firmly, screw a nanoViper fitting finger tight into the nanoZero® until you reach a firm stop.

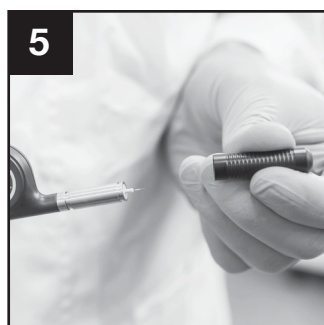

Remove protective cap.

Note: The emitter is not protected by a sheath and protrudes from the end of the cassette. To avoid damaging the emitter, ensure that the cap is removed in line with the cassette using a swift motion to completely separate the cap and the cassette.

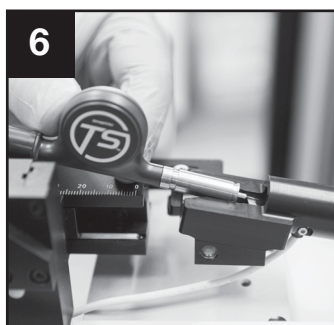

Slide column cassette into TS Nanospray Flex Adapter along the column holder until it clicks into place.

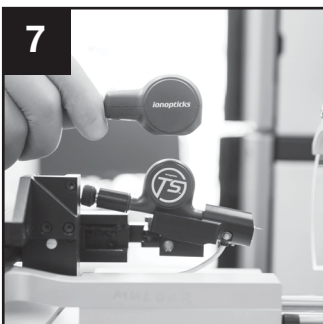

Place the IonOpticks Heater onto the fin of the column cassette and press down firmly to ensure that the heater is held in position.

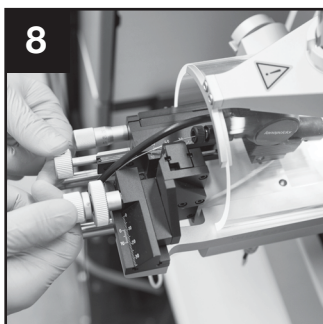

Slide the stage into position and adjust the x, y and z axis to ensure a good emitter position. The emitter should be around 3 mm from the ion transfer tube.



The column is now installed and ready for operation.

Removal of TS column from your system.

1. If possible, do not remove the column from a UHPLC system before the column performance falls and the columns requires replacement, however, removal for instrument servicing and maintenance is sometimes required.
2. For the removal procedure, run 80% B for 5min at operating flow rates.
3. Reduce flow to 0.002 $\mu\text{l}/\text{min}$ for 10 min or until the back pressure has stabilised below 10 bar.
4. Set MS system into standby mode.
5. Slide Nanospray Flex stage out of the safety hood before sliding the column cassette backwards from the TS Nanospray Flex Adapter along the column holder.
6. The nanoViper can now be removed from the nanoZero®.
7. Carefully place the protective cap back onto the cassette and press firmly to ensure that the cap is held securely.
8. Screw the shipping plug into the nanoZero®. For removal of the column for extended periods of time we recommend placing 30 μl of methanol in the nanoZero® before installing the shipping plug.

Note: Removal of the nanoViper from the nanoZero under high back pressure conditions can damage the stationary phase bed and lead to blockages and poor chromatographic performance.

Note: The removal procedure can lead to fouling of the emitter tip and poor column performance. The IonOpticks replacement guarantee is not valid if a column has been removed from a UHPLC once in operation.

For Thermo EasySpray source (ES081 and ES082) with IonOpticks Aurora TS



1 Remove the shipping plug from the column cassette.

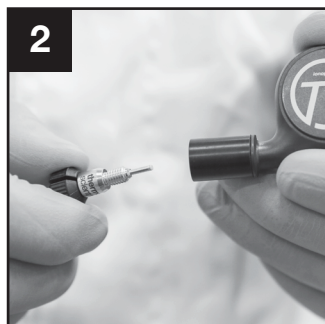

2 Holding the column cassette firmly, screw a nanoViper fitting finger tight into the nanoZero® until you reach a firm stop.

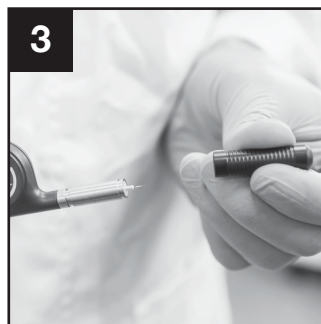

3 Remove protective cap.

Note: The emitter is not protected by a sheath and protrudes from the end of the cassette. To avoid damaging the emitter, ensure that the cap is removed in line with the cassette using a swift motion to completely separate the cap and the cassette.

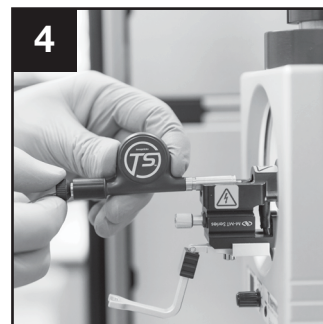

4 Ensure the Z-axis control knob has been set in the correct position using the Thermo emitter positioning tool. If no tool is available, ensure that the control knob has been retracted to prevent the emitter contacting the ion transfer tube when the column is inserted.

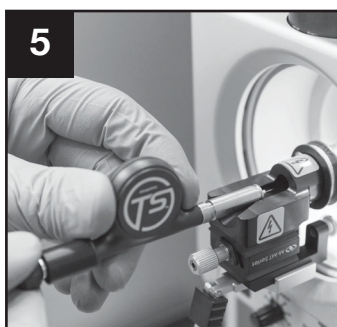

5 Slide column cassette into EasySpray source along the column holder until it clicks into place.

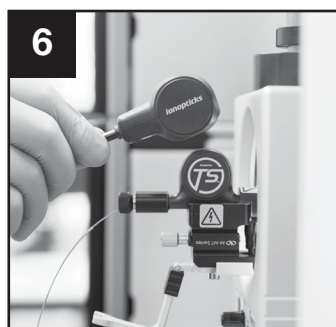

6 Place the IonOpticks Heater onto the fin of the column cassette and press down firmly to ensure that the heater is held in position.



7 Using the video feed from the source mounted camera, make fine adjustments to the z-axis emitter position as required. The emitter should be around 3 mm from the ion transfer tube. Please follow the instructions from the EasySpray Source

The column is now installed and ready for operation.

Removal of Aurora TS column from your system.

1. If possible, do not remove the column from a UHPLC system before the column performance falls and the columns requires replacement, however, removal for instrument servicing and maintenance is sometimes required.
2. For the removal procedure, run 80% B for 5min at operating flow rates.
3. Reduce flow to 0.002 µl/min for 10 min or until the back pressure has stabilised below 10 bar.
4. Set MS system into standby mode.
5. Slide column cassette backwards from EasySpray source along the column holder.
6. The nanoViper can now be removed from the nanoZero®.
7. Carefully place the protective cap back onto the cassette and press firmly to ensure that the cap is held securely.
8. Screw the shipping plug into the nanoZero®. For removal of the column for extended periods of time we recommend placing 30µl of methanol in the nanoZero® before installing the shipping plug.

Note: Removal of the solvent line from the nanoZero under high back pressure conditions can damage the stationary phase bed and lead to blockages and poor chromatographic performance.

Note: The removal procedure can lead to fouling of the emitter tip and poor column performance. The IonOpticks replacement guarantee is not valid if a column has been removed from a UHPLC once in operation.

For SCIEX OptiFlow Turbo V source with IonOpticks Aurora SX



Adjustment of the nano probe using the SX Installation Toolkit (SXITK01).

Ensure the nanoflow probe is clear of any obstructions:

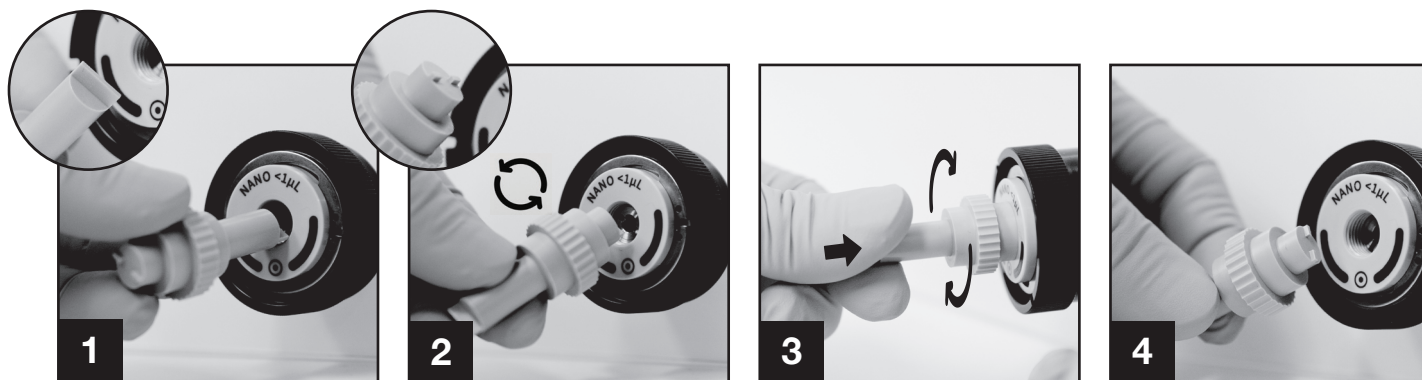

1 Insert the retraction end of the SX probe-adjustment tool into the nano probe, aligning the blade with the slot of the metal fitting inside. Turn the tool anticlockwise to reduce the depth of the metal fitting until 3 or 4 threads of PEEK are visible.

2 Flipping the SX probe-adjustment tool over, insert the depth-setting end of the tool into the nano probe, aligning the two projections with the slot of the metal fitting inside.

3 Rotate the probe-setting tool clockwise while pushing it gently towards the slotted metal fitting. Continue rotating the tool half a turn after the stepped feature of the tool makes full contact with the face of the probe.

4 Gently remove the tool from the probe.

Start with the nanoflow probe installed in the axial port of an OptiFlow Turbo V ion source.

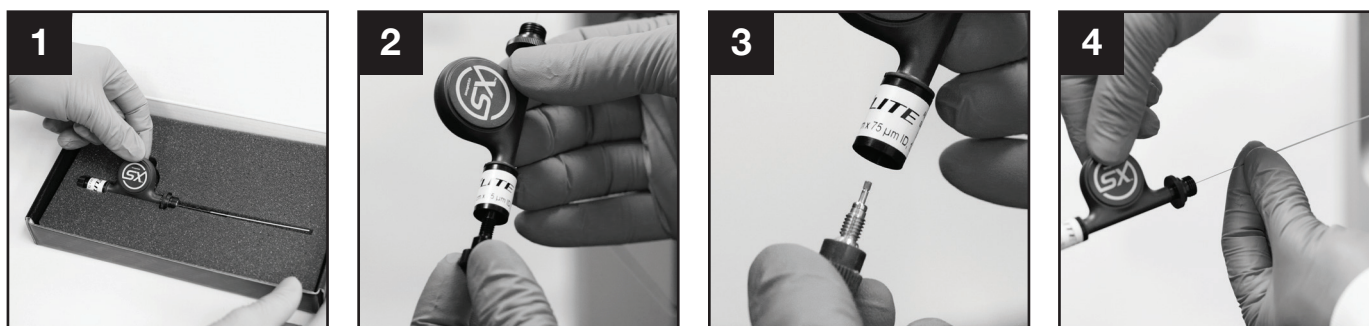

1 Wearing clean powder-free gloves, grip the main cassette body to remove the SX column from its box. **Do not remove the beige sleeve over the emitter.**

2 Turn the shipping plug counterclockwise to remove it.

3 Ensure the LC flow is set to zero then insert the solvent line fitting (ZenFit or nanoViper) into the nanoZero® fitting and rotate the finger grip on the solvent line fitting until a firm stop is reached.

4 Hold the column cassette fin in one hand and pinch the interface of the column and sleeve between a thumb and pointer finger to hold the sleeve in place (protecting the emitter tip).

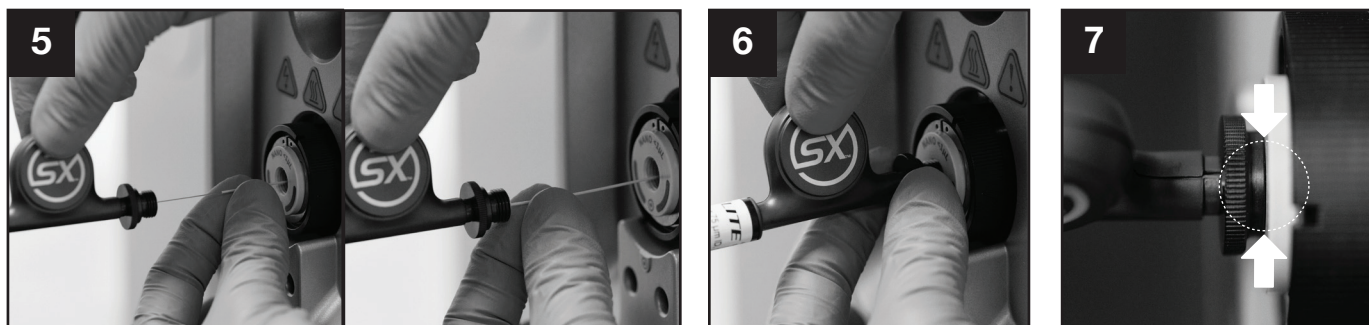

5 Maintain grip on the interface between the sleeve and column, then guide the sleeve into the orifice of the nano probe installed on the source. Push the column with sleeve into the nano probe approximately 3 cm. Maintain the position of the column cassette, then retract the sleeve towards the cassette as far as possible.

6 Push the column fully inside the probe until the thread of the black thumbwheel reaches the face of the nano probe. Hold the column cassette perpendicular to the probe, then rotate the black thumbwheel clockwise to screw it into the probe.

7 Tighten the thumbwheel securely. When a firm stop is reached, the black O-ring is no longer visible when viewed from the side.

For SCIEX OptiFlow Turbo V source with IonOpticks Aurora SX



Installing the SX Adapter and IonOpticks column heater.



You will need:
1 x SX Adapter
for the following steps.

(The SX Adapter is included in the
SX Installation Toolkit SXITK01)

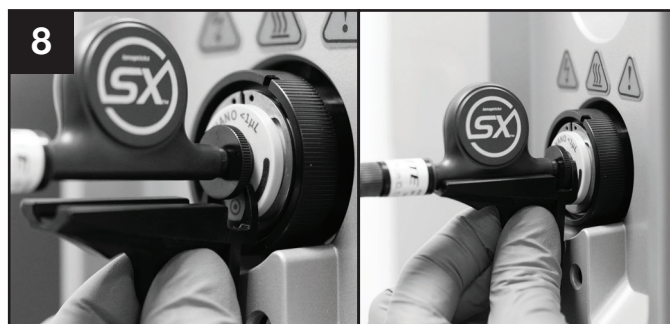

8 Grip the SX Adapter via the concave feature on each side. Install it by placing it underneath the column cassette with the prongs facing upwards and touching the beige probe face. Hold the adaptor level and then slide it upwards until it clicks in place under the column.

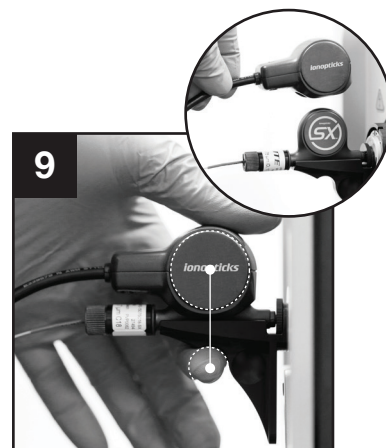

9 Holding the IonOpticks heater level, place it onto the fin of the column cassette, positioned so that the centre point of the heater is perpendicular with the finger notch on the SX adapter. Use the finger notch to pinch and apply pressure to the heater until it makes contact with the adapter.

**The column is now installed
and ready for operation**

Removal of Aurora SX column from your system.

1. If possible, do not remove the column from a UHPLC system before the column performance falls and the columns requires replacement, however, removal for instrument servicing and maintenance is sometimes required.
2. For the removal procedure, run 80% B for 5min at operating flow rates.
3. Reduce flow to 0.002 ul/min for 10 min or until the back pressure has stabilised below 10 bar.
4. Set MS system into standby mode.
5. Grip the SX adaptor via the concave features on each side.
6. Grip the projection at the rear of the heater where the cable attaches. Tilt the heater forwards to release.
7. Lift off the heater.
8. Grip the concave features on the adaptor.
9. Pull the adaptor straight down to release it from the column.
10. Rotate the thumbwheel counterclockwise to disengage it from the probe.
11. Pull the column straight out (perpendicularly) until the thumbwheel is approx. 3 cm from the front of the nano probe.
12. With the other hand, grip the sleeve and hold it close to the front of the nano probe.
13. Hold the sleeve in place and pull the column back until the thumbwheel is approx. 5 cm from the front of the nano probe.
14. Remove the column and sleeve from the probe.
15. Reinstall the shipping plug.
16. Place the column back in its box.

Note: Removal of the solvent line from the nanoZero under high back pressure conditions can damage the stationary phase bed and lead to blockages and poor chromatographic performance.

Note: The removal procedure can lead to fouling of the emitter tip and poor column performance. The IonOpticks replacement guarantee is not valid if a column has been removed from a UHPLC once in operation.

Operation of Aurora Series columns.

Aurora series columns initial operation

Once the column is connected to your UHPLC system and is placed inside the source heater or housing, begin operation using 70% buffer B at a flow rate equivalent to the desired gradient flow rate for around 10 minutes or until the pressure is stable for several minutes. Voltage should be applied once the mobile phase reaches the emitter tip. It is recommended that at least one gradient is run without sample injection before assessment of column performance using standards.

Spray voltage

It is recommended to start with a spray voltage of 1500V and increase over time as required to maintain a stable spray. It is recommended that the spray voltage does not exceed 2500V. Exceeding a spray voltage of 2500V may result in damage to the emitter.

Standby and idle conditions

To optimise column lifetime and performance, it is recommended that the instrument continues to run at the desired operating pressure and ideally continues to run blank samples using mobile phase gradients typical of normal operation. Spray voltages should be maintained during these operations.



Extended periods of time at isocratic flow will reduce column performance. Column performance can be recovered by running a blank gradient without sample injection.

Operating environmental conditions

The laboratory room temperature must be maintained between 15 and 27 °C (59 and 81 °F). The relative humidity of the operating environment must be between 20 and 80%, with no condensation. The operating environment of the equipment should be free of vibrations.

Removal from a UHPLC

If possible, do not remove the column from a UHPLC system, however, removal is sometimes required. For the removal procedure, run 80% B for 5min at operating flow rates before reducing flow to 0.002 µl/min for 10min or until the back pressure has stabilised below 10 bar. Set MS system into standby mode. The nanoViper can now be removed from the nanoZero®. For removal of the column for extended periods of time we recommend placing 30µl of methanol in the nanoZero® and screwing in the plug supplied during transport.



Removal of the nanoViper from the nanoZero® under high back pressure conditions can damage the stationary phase bed and lead to blockages and poor chromatographic performance.



The removal procedure can lead to fouling of the emitter tip and poor column performance. The IonOpticks replacement guarantee is not valid if a column has been removed from a UHPLC once in operation.

Recommended buffer compositions:

Buffer A 99.9% MilliQ Water, 0.1% formic acid
Buffer B 99.9% Acetonitrile, 0.1% formic acid

Column volumes

60cm X 75µm	2.65 µl
25cm X 75µm	1.1 µl
15cm X 75µm	0.66 µl
5cm X 150µm	0.88 µl
5cm X 75µm	0.22 µl

Column temperature

The recommended operating temperature for Aurora columns is 40-60 °C. The maximum operating temperature is 60 °C.

Column equilibration

Before each run the column should be re-equilibrated using a minimum of 4 column volumes of 100% buffer A.

Sample loading

Samples should be loaded onto the column in 100% Buffer A. Samples loaded on to the column should be de-salted and should not contain any contaminants (salts, detergents, solid particles, etc). Loading contaminated samples onto the column may disrupt solvent flow or foul the emitter tip leading to a loss of performance.

Example data

Example data and raw data files for each column can be provided upon request. Please contact support@ionopticks.com for more information.

Example gradients.

Aurora Frontier™

60 cm x 75 µm

Recommended gradient: 90-180 mins

Example gradient:

Time (min)	Comp (% Buffer B)	Flow Rate (µl/min)
0	0	0.25
2	3	0.25
114	17	0.25
156	25	0.25
182	34	0.25
184	85	0.25
200	85	0.25

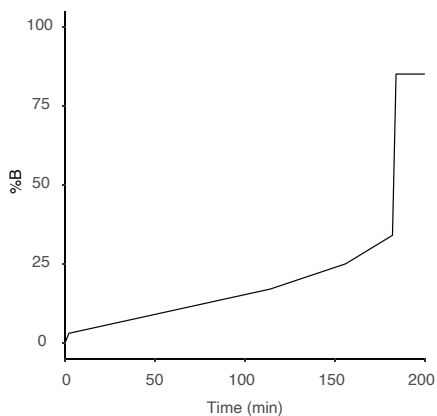

Aurora Ultimate™

25 cm x 75 µm

Recommended gradient: 45-120 mins

Example gradient:

Time (min)	Comp (% Buffer B)	Flow Rate (µl/min)
0	0	0.4
1	3	0.4
57	17	0.4
78	25	0.4
91	34	0.4
92	85	0.4
100	85	0.4

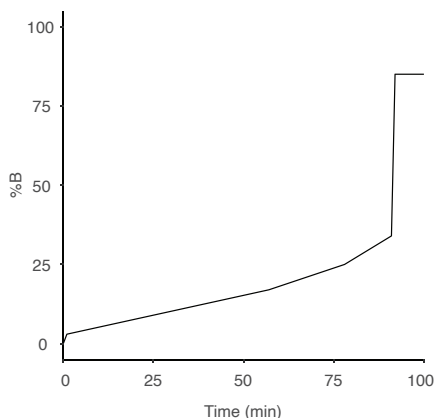

Aurora Elite™

15 cm x 75 µm

Recommended gradient: 10-45 mins

Example gradient:

Time (min)	Comp (% Buffer B)	Flow Rate (µl/min)
0	5	0.4
17	30	0.4
17.5	85	0.4
20	85	0.4

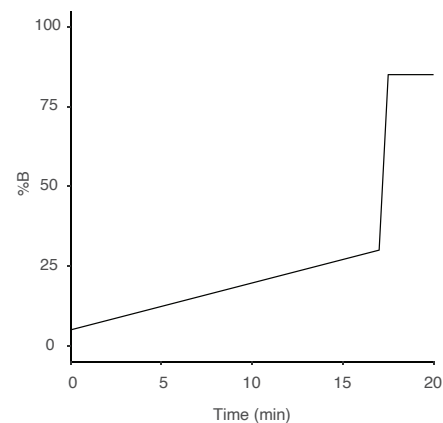

Aurora Rapid75™

5 cm x 75 µm

Recommended gradient: 5-15 mins

Example gradient:

Time (min)	Comp (% Buffer B)	Flow Rate (µl/min)
0	0	0.1
1	3	0.1
10	30	0.1
11	85	0.1
14	85	0.1
14.1	0	0.1
15	0	0.1

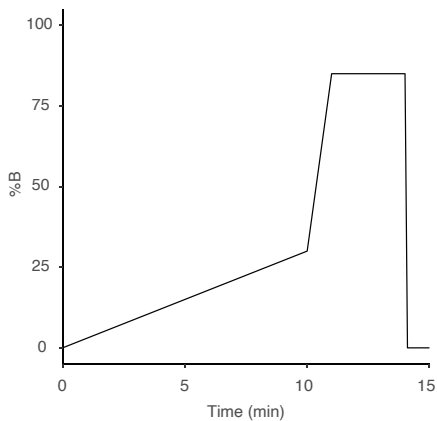

Aurora Rapid150™

5 cm x 150 µm

Recommended gradient: 5-15 mins

Example gradient:

Time (min)	Comp (% Buffer B)	Flow Rate (µl/min)
0	5	2
5	34	2
5.5	85	2
6.5	85	2
6.8	0	2
7.5	0	2

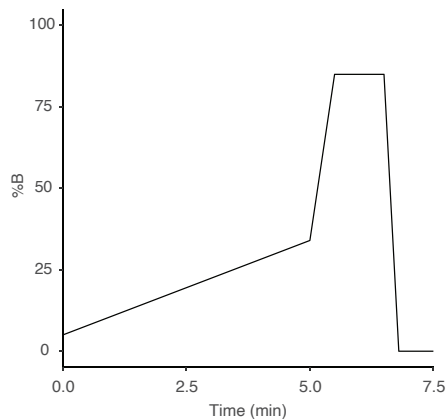



Need help?

Visit helpcentre.ionopticks.com

ionopticks

68-70 Hanover Street
Fitzroy VIC 3065
Australia

www.ionopticks.com

© Copyright 2023
All rights reserved.

'nanoZero' is a © Registered Trademark of IonOpticks Pty Ltd.
'Aurora Frontier', 'Aurora Ultimate', 'Aurora Elite' and 'Aurora Rapid' are trademarks of IonOpticks Pty Ltd.